



**2021-22 EXCLUSION FENCING CATALOGUE**



**Visit [waratahfencing.com.au](http://waratahfencing.com.au) or phone 13 10 80**

# WARATAH® EXCLUSION FENCING RANGE

The Waratah range of products have been designed to make fencing easier, faster and more cost effective over the life of your fence. Our innovative range of products can be tailored to suit a range of applications or conditions across rural Australia.

Waratah has a range of products designed for exclusion fencing. Whether it's to prevent animals burrowing under the fence, jumping and climbing over or going through the fence, the Waratah team can help you find the right products for your exclusion fencing needs.

This publication contains general information on Waratah's range of exclusion fencing products and sample fence designs to provide effective protection for your enterprise. Performance of the products will depend on many factors including installation, animal pressure, weather and soil conditions.

## WHY BUY WARATAH?

When you invest in a Waratah fence, you're investing in the following Waratah values. It's these values that set Waratah apart from any other fencing supplier:

- ✓ KNOWLEDGE AND SERVICE
- ✓ CONSISTENCY AND QUALITY
- ✓ RANGE AND INNOVATION
- ✓ PROVEN IN THE FIELD FOR OVER 135 YEARS

**FOR MORE FENCING PRODUCTS, TOOLS AND ACCESSORIES SEE OUR 2021-2022 FENCING CATALOGUE.**

**TALK TO WARATAH FENCING TODAY, WE'D LIKE TO HELP YOU MAKE THE RIGHT DECISIONS WHEN CONSIDERING YOUR FENCING REQUIREMENTS.**



13 10 80



[www.waratahfencing.com.au](http://www.waratahfencing.com.au)



search 'Waratah Fencing'

# POSTS

The key to a fence's strength and longevity, Waratah posts are the superior quality backbone to a better performing fence.

# WIRE

Quality wire is essential for the life and performance of your fence. Longlife Blue® fence wire uses innovative technology, exclusive to Waratah®, that's been tried and tested in the field for over 20 years.

# ACCESSORIES

Save time, maintenance and money by having the right tools for the job with Waratah's market-leading range of tools and accessories.

## EZYPIPE® STRAINER POST

The Waratah® round post alternative to traditional timber, pipe and concrete strainer posts.

### SPECIFICATIONS

Pipe:	89mm (OD) x 4mm (wall)
Material:	250 grade pipe
Coating:	Hot dipped galvanized (min 300g/m <sup>2</sup> )
Lengths available:	2.15m, 2.50m, 3.25m

Apron strainers available on page 14. Gate fittings also available – see the Waratah 2021-2022 fencing catalogue or [www.waratahfencing.com.au](http://www.waratahfencing.com.au)

POST	ABOVE GROUND (mm)	IN GROUND (mm)
Ezypipe 2.15m	1300	850
Ezypipe 2.50m*	1400-1600	900-1100
Ezypipe 3.25m	2050	1200

\* Adjustable collar locations using pre-drilled holes - collar comes pre-set at second hole (1500mm above ground), but can be adjusted to 1400mm or 1600mm above ground.

## EZYSLOT® STRAINER POST

The fastest and easiest Waratah strainer post to manually install.

### SPECIFICATIONS

Angle:	75mm x 75mm x 6mm
Material:	300 grade pipe
Coating:	Hot dipped galvanized (min 600g/m <sup>2</sup> )
Lengths available:	2.10m, 2.50m

Apron strainers available on page 14. Gate fittings also available – see the Waratah 2021-2022 fencing catalogue or [www.waratahfencing.com.au](http://www.waratahfencing.com.au)

POST	ABOVE GROUND (mm)	IN GROUND (mm)
Ezyslot 2.10m	1250	850
Ezyslot 2.50m	1350	1150

## ADJUSTA-STAY®

One of the most versatile stays on the market. Can be used with the Ezyslot, Ezypipe and most timber, concrete or pipe strainer posts.

### SPECIFICATIONS

Pipe:	50NB pipe x 60.30mm (OD) x 2.30mm (wall) x 3m length
Coating:	Hot dipped galvanized (min 300g/m <sup>2</sup> )
Hot dipped tension rod lengths:	3.25m x M12 (12mm) with nuts and washers
Ground engaging pad:	Plastic





### JiO® STAR®

- › The original Waratah® Y shape fence post, but 10% stronger & 3 times more ductile with oval holes for JiO clips
- › Lengths available: 135cm, 150cm, 165cm, 180cm, 210cm, 225cm, 240cm and 270cm
- › Hot dipped galvanized (600g/m<sup>2</sup>) coating ensures exceptional corrosion protection, extended post life and added strength in your fence line\*
- › More holes for improved wire alignment and attachment options
- › Post extensions for retrofitting available – see page 15

\* Some soils can be extremely corrosive to zinc and other coatings - ultimately these factors will determine the life and performance of the product



### JiO MAXY®

- › Waratah's biggest and strongest fence post, double the profile of the JiO Star
- › An easier to handle intermediate post compared to concrete or timber
- › Lengths available: 180cm, 210cm, 225cm, 240cm and 270cm
- › Hot dipped galvanized (600g/m<sup>2</sup>) coating ensures exceptional corrosion protection\*
- › More holes for improved wire alignment and attachment options

\* Some soils can be extremely corrosive to zinc and other coatings - ultimately these factors will determine the life and performance of the product



### BLUE LATCH™ POST

- › The Waratah Blue Latch post is 40% larger than the JiO Star post providing additional ground holding and resistance to movement
- › Quick installation of the fence with no need to use tie wire or clips. Just position the fence wire into the latch
- › Waratah Longlife Blue coated spring wire latches for maximum corrosion protection when in contact with the fence wire
- › Hot dipped galvanized coating of 600g/m<sup>2</sup> for corrosion protection
- › 33% stronger than a Waratah JiO Star of the same length

POST*	POSTS LISTED ARE COMPATIBLE WITH
210cm <sup>^</sup> , 225cm & 240cm	12/115/15 prefabricated wire 15/150/15 prefabricated wire 16/180/15 prefabricated wire

\*Blue Latch posts are only compatible with these sizes.

<sup>^</sup>210cm post is not suited for top line of barbed or plain wire

## WHY BUY LOGLIFE BLUE?

Good quality fence wire, whether plain, barbed, prefabricated or netting, is key to the life of a fence. If you want a fence that lasts, you'll need Australia's leading fence wire, Waratah® Longlife Blue.

### WARATAH IS THE ONLY VERTICALLY INTEGRATED AUSTRALIAN WIRE MANUFACTURER

As Australia's only long steel and wire manufacturer, Waratah controls every step in the process, from smelting the steel, casting the billet, through to rolling the rod and then drawing and coating the wire to Waratah's exacting standards.

### PREMIUM WIRE CORE

At the centre of Longlife Blue's performance advantage is a premium steel wire core.

The quality and consistency of the wire core provides strength, makes it easier to handle and means less breaks.

### PREMIUM WIRE COATING

Longlife Blue wire products are coated with Zalcote® and Permaseal® technologies – exclusive to Waratah.

Longlife Blue coating is proven in the lab and in the field for over 20 years.

Not just a claim, Longlife Blue is "real-time tested" in the field to last at least 9 times longer than standard galvanized wire and at least 1.5 times longer than heavy galvanized wire.

Manufactured in Australia to exceed Australian Standards, NATA & Waratah's high standards.

### LOGLIFE VS STANDARD AND HEAVY GALVANIZED WIRE

#### WIRE CORE

- Longlife Blue wire has a thicker wire core, making the wire stronger and more reliable than equivalent heavy galvanized wire

#### WIRE COATING

- Longlife Blue outperforms standard and heavy galvanized wires

## IF IT'S NOT BLUE, IT'S NOT WARATAH!



**WARATAH WIRE**  
The wire core is made with the finest quality steel.

**ZALCOTE® COATING**  
The zinc aluminium coating provides barrier and galvanic protection of the steel that does not fracture or flake when tying off.

**TERNARY LAYER**  
A coating layer closest to the wire core comprising of zinc/ aluminium/iron. This layer is enriched in aluminium - enhancing both ductility and corrosion protection. This is the most important layer for the coating performance and is ensured to be "intact" and complete all around the wire.

**PERMASEAL® BLUE COATING**  
The organic polymer layer of the Permaseal not only gives Longlife Blue colour® its unique look, but also adds further protection.



For more information see the Waratah 2021-2022 fencing catalogue or [www.waratahfencing.com.au](http://www.waratahfencing.com.au)



## EXCLUSION FENCING



Waratah's exclusion product range has been designed to make fencing easier, faster and cost effective. The innovative range of products can be tailored to suit a range of applications or conditions across rural Australia. Specifically, exclusion fences aim to prevent feral animals from accessing properties.

Whether you are installing a fence to prevent animals burrowing, jumping, climbing over or going through the fence, Waratah has the right products for your exclusion fencing needs.

## LIVESTOCK FENCING

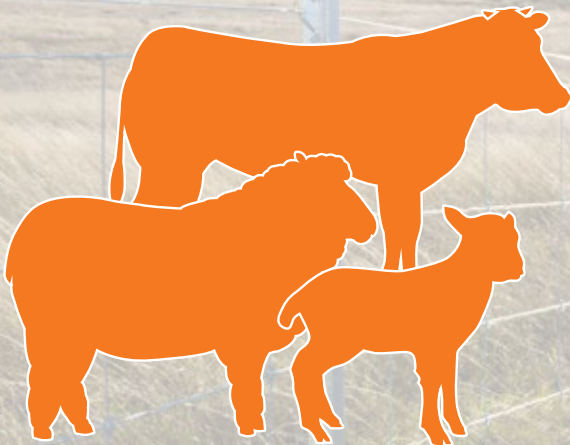

The Waratah Fencing System™ can cover an enormous range of fencing options to withstand differing environmental conditions and terrain, and to suit your unique needs for animal containment. With a range of products to suit your livestock and new longer rolls to reduce the amount of joins in your fence Waratah has your livestock fencing needs covered.

## CONSERVATION



Feral animals continue to threaten wildlife, flora & fauna. The most effective solution is conservation fencing which acts as a physical barrier against digging, climbing & jumping feral threats while also ensuring that native animals are protected. Conservation fencing will only be effective if it is designed, built & maintained using proven fencing products & solutions.



# STOCKSAFE-T® LONGLIFE BLUE®



Specifically designed to prevent animals penetrating the fence, the rigid knot resists vertical wires from being separated. This reduces the chance of feral animals penetrating the fence. Available with or without pre-attached 30cm hinged apron.

WIRE SIZE	ROLL LENGTH (M)
16/180/15 <sup>^</sup>	500
15/150/15	100
12/115/15	250
11/90/15	100
8/90/30	200 & 500*
8/90/15*	500
2.00mm Line Wires	
13/90/15	100

WIRE SIZE WITH APRON	ROLL LENGTH (M)
15/150/15	100, 250 & 500
12/115/15	250
11/90/15	100
8/90/15*	250

See Waratah 2021-2022 fencing catalogue for all sizes or [www.waratahfencing.com.au](http://www.waratahfencing.com.au)

<sup>^</sup>Available as made to order product

\*Can be used for internal fencing







## STOCKGRIP® LONGLIFE BLUE®



The prefabricated fence wire design is favoured for longer spans and suspension fence designs. The single picket wire has a “dropper” effect and creates a stiffness in the fence, whilst the knot allows for some movement of both the picket and horizontal (line) wire. This unique feature allows the fence to absorb impact and spread load. Available with or without pre-attached 30cm hinged apron.

WIRE SIZE	ROLL LENGTH (M)
16/180/15^	250
15/150/15	250
12/115/15	250
11/90/15*	100
8/90/30	200
8/90/15	100

^Used as a radius apron

WIRE SIZE WITH APRON	ROLL LENGTH (M)
15/150/15	250
12/115/15	250
11/90/15	100

See Waratah 2021-2022 fencing catalogue for all sizes or [www.waratahfencing.com.au](http://www.waratahfencing.com.au)

\*Can be used for internal fencing

## LOGLIFE BLUE® NETTING

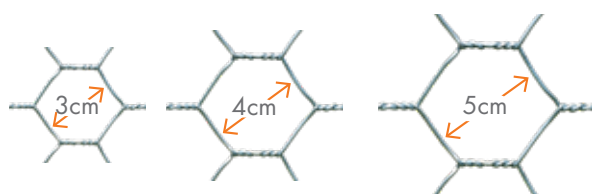

Two-ply selvage wire is used to give the netting added strength. For tighter exclusion applications, the 3cm mesh spacing is recommended to prevent smaller animals such as baby rabbits (kittens) from penetrating the fence. 1.80mm netting is ideally suited to high pressure situations like wombats, emus, pigs and dogs.

WIRE SIZE	ROLL LENGTH (M)
4.0cm mesh	1.40mm wire
30/4.0/1.40	100
60/4.0/1.40	100
90/4.0/1.40	50 & 100
105/4.0/1.40	50 & 100
180/4.0/1.40	50

4.0cm mesh	1.80mm wire
30/4.0/1.80	100
60/4.0/1.80	100
90/4.0/1.80	50 & 100
105/4.0/1.80	50 & 100
180/4.0/1.80	50

3.0cm mesh	1.40mm wire
30/3.0/1.40	100
60/3.0/1.40	100
90/3.0/1.40	50 & 100
105/3.0/1.40	50 & 100
120/3.0/1.40	50 & 100

5.0cm mesh	1.60mm wire
90/5.0/1.60	50
120/5.0/1.60	50
180/5.0/1.60	50

See Waratah 2021-2022 fencing catalogue for all sizes or [www.waratahfencing.com.au](http://www.waratahfencing.com.au)



## 2.00mm HIGH TENSILE LONGLIFE BLUE® BARBED WIRE

> The strongest in the range, it is recommended for high pressure situations. Reverse twist pattern provides maximum strength and safety



DIAMETER



2.00mm

BREAKING STRAIN



5.0kN

RECOMMENDED TENSION



1.6kN

LENGTH



500m

## 2.80mm HIGH TENSILE LONGLIFE BLUE FENCE WIRE

> The strongest high tensile wire in our range and is recommended for high pressure situations such as cattle and exclusion fences and also for the top wire, when strength is vital



DIAMETER



2.80mm

BREAKING STRAIN



8.0kN

RECOMMENDED TENSION



2.0kN

LENGTH



1000m

## STOCKTITE® LONGLIFE BLUE SKIRT



> The Stocktite skirt is a dedicated section that can be attached to existing fence or new fence lines as an apron layout to deter animals from burrowing under the fence. Manufactured with 2.00mm high tensile line wires



WIRE SIZE	ROLL LENGTH (M)
6/51/15	300



## TENSER SENSER® WIRE TENSIONING GAUGE

- › Indicates approximate wire tension to more accurately strain wire – helping to prolong fence life and reduce maintenance time and costs
- › Pre-assembled and calibrated for immediate use



## RINGMASTER® PNEUMATIC CLIP GUN

- › A fast, easy way to secure clips to fence wires, reducing physical effort and increasing the number of clips installed per hour
- › Designed for use with Waratah® Ringmaster Longlife Blue® clips
- › Recommended air pressure: optimum 80PSI. Do not operate above 100PSI



## RINGMASTER LONGLIFE BLUE CLIPS

- › Effectively secures all types of fence wire
- › Recommended for use with the Waratah Ringmaster clip gun
- › Made from 1.80mm Longlife Blue wire
- › Minimum of 100 clips on each strip



## CONTRACTOR WIZARD® WIRE STRAINER

- › Grips wire securely to efficiently tension plain and barbed fence wire
- › Can be used with the Wedglock® clamp (also available for purchase) when straining prefabricated wire
- › 4.50m chain with longer handle for easier operation and more leverage (30% less effort)
- › Longer swivel handle and clearance notches allow a greater angle of action

For the full range of tools and accessories see the Waratah 2021-2022 fencing catalogue or [www.waratahfencing.com.au](http://www.waratahfencing.com.au)



## CONTRACTOR WEDGELOCK® CLAMP

- › Holds prefabricated wire and netting in place while Wizard® wire strainers (connected top and bottom of the clamp) evenly tension the wire
- › Additional wedge for tighter securing of top and bottom selvedge wires when straining 1.5m or higher prefabricated fences
- › Available in 1.60m, 1.90m and 2.00m lengths
- › The contractor Wedgeloak clamp was designed and tested for use by fencing professionals. Featuring top and bottom holes for use with D-shackles rather than hooks. Commonly used for longer strain fencing



## THUMPA® PNEUMATIC POST DRIVER

- › An easy way to drive JiO® Star®, JiO MaxY® and Blue Latch™ posts into virtually any terrain faster than a manual driver, saving time and money
- › Change between post types in seconds with a simple twist and release system (other attachments available)
- › Can also be attached to a mechanically assisted device on a vehicle to assist lifting the driver on and off posts



## GRIPPLE PLUS™ & CONTRACTOR TOOL

- › Gripple Plus wire joiners save time and effort when joining wires, tensioning or terminating wire at a strainer post
- › The patented ceramic locking mechanism delivers a strong grip and can take higher loads
- › Available in small, medium and large for different wire sizes. Gripple Plus medium are recommended for exclusion fencing
- › Housing is die-cast zinc for superior corrosion protection
- › Contractor tensioning tool designed to deliver a mechanical advantage of 10:1, which means less effort is required to tension wire to the recommended tension



## GRIPPLE® T-CLIP™ /T-CLIP LARGE

- › A great alternative to tying off wire around strainer posts – no need for knots, twisting or staples, saving both time and labour
- › T-Clip suitable for 1.80mm-3.25mm wire
- › Use the T-Clip at either end of the fence line to tie-off wire
- › Allows consistent replication and is up to 5 times faster than a manual tie-off
- › Housing is die-cast zinc for superior corrosion protection
- › Recommended for round strainer posts
- › T-clip large suitable for 4.00mm plain wire and barbed wire



## JiO® POST CLIPS

- › Effectively secure fence wires to JiO posts, up to 20% faster than traditional clips
- › Simple and easy to use – no tools required
- › Made from Longlife Blue® wire
- › Allows for wire movement under impact



## CUT-LENGTH TIE WIRE

- › Conveniently pre-cut 30cm straight wire lengths to save time with no sharp ends for safe use
- › Made from Longlife Blue wire
- › Ideal for tying wire to the back of the posts
- › Available in packs of: 2.50mm x 300mm lengths  
3.15mm x 300mm lengths



## APRON STRAINER EXTENSION

- › Allows for apron layouts on fences to be strained. Steel loop allows for a Waratah® Star® post to be driven through the end as a brace
- › Can be attached to both flat and round strainers
- › Hot dipped galvanized for superior corrosion protection
- › Apron strainer has a length of 45cm



## UMBRELLA POST EXTENSION

- › Each extension comes with a galvanized clip and galvanized bolt to secure the extension onto existing steel Star® posts
- › Heavy galvanized for superior corrosion protection
- › Manufactured loops on the extension allows for secure placement of selvedge wire
- › To be used in conjunction with the umbrella strainer extension
- › Half umbrella is 450mm to be used with a 600mm floppy top
- › Umbrella is 900mm to be used with a 1200mm top apron



## UMBRELLA STRAINER EXTENSION

- › Suitable for use with Ezypipe® strainer post. Slots into the top of the pipe
- › Hot dipped galvanized for superior corrosion protection
- › Use in conjunction with the umbrella or half umbrella post extensions for horizontal netting applications
- › Available in 900mm and half umbrella 450mm
- › Secures onto the strainer post with metal screws



## POST EXTENSIONS

- › A straight, 45 degrees or 90 degrees extension that can be attached to Star posts
- › Unique JiO® holes allow the use of JiO clips, electric and related accessories



## EZYPIPE STRAINER EXTENSION

- › An end assembly post extension that can be attached to Ezypipe strainer posts
- › Secures onto the strainer post with metal screws
- › Available in 45 degrees or 90 degrees extensions

# SAMPLE FENCE DESIGNS

The following section contains a sample of commonly used exclusion fence designs, using the Waratah Fencing System™.

Performance of the products will depend on many factors including installation, animal pressure, weather and soil conditions. To discuss your exclusion fence design contact our Waratah Customer Service team on 13 10 80.





## STOCKSAFE-T® LONGLIFE BLUE® 15/150/15 WITH APRON

The Waratah® Stocksafe-T fence design may be used as an external boundary fence to prevent animals such as kangaroos, wild dogs and wallabies from penetrating the fence. For added height post extensions can be added to each post and strainer. For protection against animals burrowing under the fence Stocksafe-T is available with an apron which can be secured using the apron strainer extension.

### FENCE FEATURES

#### Posts:

- › Ezypipe® strainer post 3.25m
- › Adjusta-stay®
- › 225cm Blue Latch™ or 210cm Blue Latch posts, 225cm JiO® Star® or JiO MaxY® posts

#### Wire:

- › Stocksafe-T Longlife Blue 15/150/15 with apron
- › 2.00mm high tensile Longlife Blue barbed wire

#### Accessories:

- › Gripple® T-Clip™
- › Apron strainer extension

#### Tools:

- › Ezypipe strainer post driver
- › Thumpa® pneumatic post driver
- › Contractor Wizard® wire strainer
- › Contractor Wedgelock® clamp
- › Tenser Senser® wire tensioning gauge

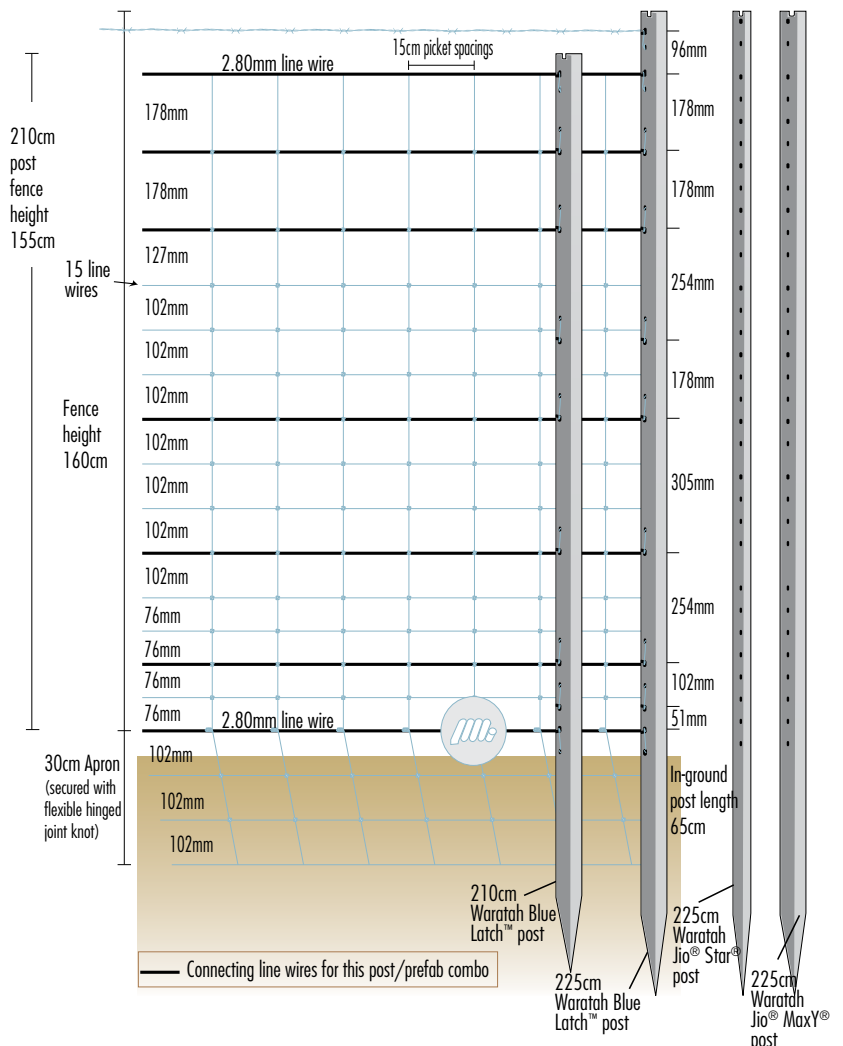



## STOCKSAFE-T® LONGLIFE BLUE® 12/115/15 WITH APRON

The Waratah® Stocksafe-T fence design may be used as an external boundary fence to prevent animals such as kangaroos, wild dogs and wallabies from penetrating the fence. For added height post extensions can be added to each post and strainer. For protection against animals burrowing under the fence Stocksafe-T is available with an apron which can be secured using the apron strainer extension.

### FENCE FEATURES

#### Posts:

- > Ezy pipe® strainer post 3.25m
- > Adjusta-stay®
- > 210cm Blue Latch™ post or 210cm JiO® Star® or JiO MaxY® post

#### Wire:

- > Stocksafe-T Longlife Blue 12/115/15 with apron
- > 2.00mm high tensile Longlife Blue barbed wire
- > 2.80mm high tensile Longlife Blue fence wire

#### Accessories:

- > Gripple® T-Clip™
- > Apron strainer extension

#### Tools:

- > Ezy pipe strainer post driver
- > Thumpa® pneumatic post driver
- > Contractor Wizard® wire strainer
- > Contractor Wedgelock® clamp
- > Tenser Sensor® wire tensioning gauge

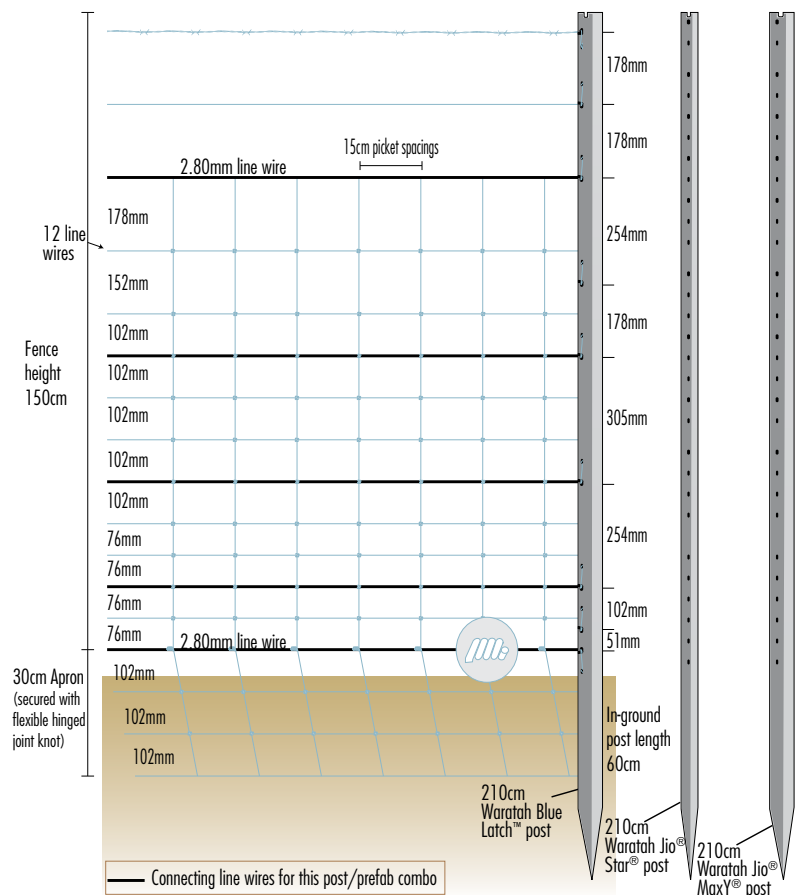



## STOCKGRIP® LONGLIFE BLUE® 16/180/15

The Waratah® Stockgrip fence design may be used as an external boundary fence to prevent animals such as kangaroos, wild dogs and wallabies from penetrating the fence. For protection against animals burrowing under the fence Stockgrip has a section which can be laid out against the ground. For added height post extensions can be added to each post and strainer.

### FENCE FEATURES

#### Posts:

- › Ezy pipe® strainer post 3.25m
- › Adjusta-stay®
- › 240cm Blue Latch™ post\* or 225cm Blue Latch post or 210cm Blue Latch post

#### Wire:

- › Stockgrip Longlife Blue 16/180/15
- › 2.00mm high tensile Longlife Blue barbed wire

#### Accessories:

- › Gripple® T-Clip™
- › Apron strainer extension

#### Tools:

- › Ezy pipe strainer post driver
- › Thumpa® pneumatic post driver
- › Contractor Wizard® wire strainer
- › Contractor Wedgelock® clamp
- › Tenser Senser® wire tensioning gauge

\*The 240cm post provides extra holding capacity in ground. The bottom latch is designed for optional plain or barbed wire.

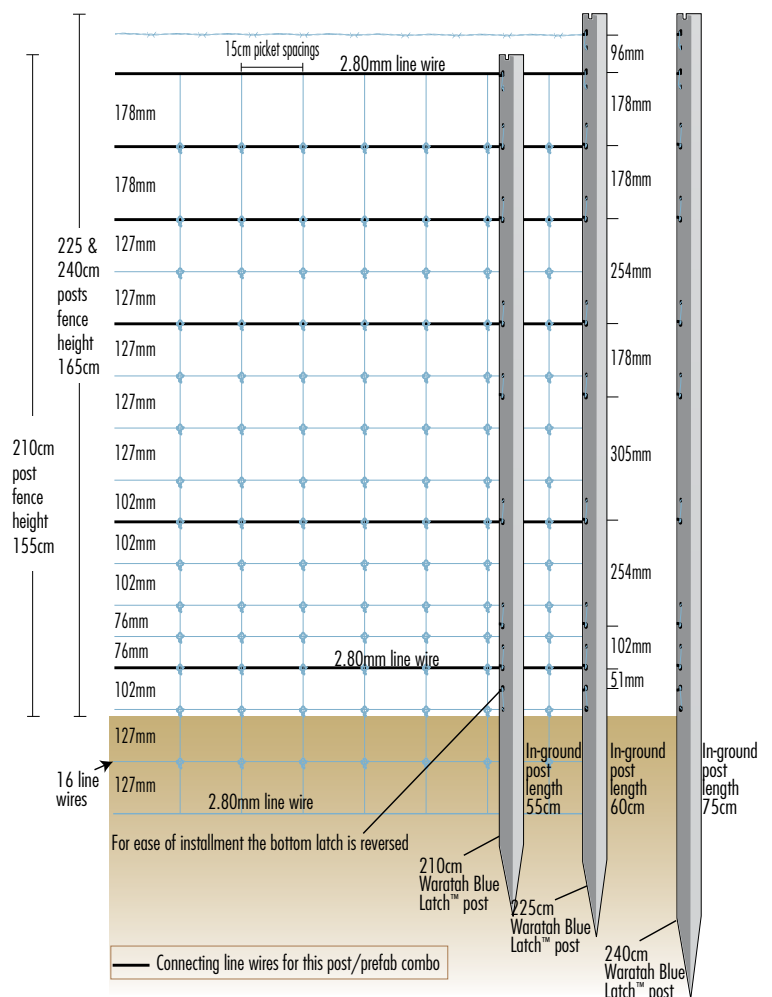



## WARATAH RETROFIT FENCE

Retrofitting is the economical way of transforming an older fence into an exclusion fence. Waratah® has a range of accessories that can help improve your fence. Our Stocktite® skirt helps deter animals from burrowing under the fence and adding post extensions (either 90°, 45° or vertical) may help prevent high jumping animals.

### FENCE FEATURES

#### Posts:

- › Existing farm fence posts

#### Wire:

- › Existing farm fence
- › Stocktite Longlife Blue® skirt 2.00mm 6/51/15
- › 2.80mm high tensile Longlife Blue fence wire

#### Accessories:

- › JiO® post clips
- › Ringmaster® Longlife Blue clips
- › Gripple® T-Clip™
- › 90°, 45° or vertical post extension
- › Apron strainer extension

#### Tools:

- › Contractor Wizard® wire strainer
- › Contractor Wedgelock® clamp
- › Ringmaster® pneumatic clip gun

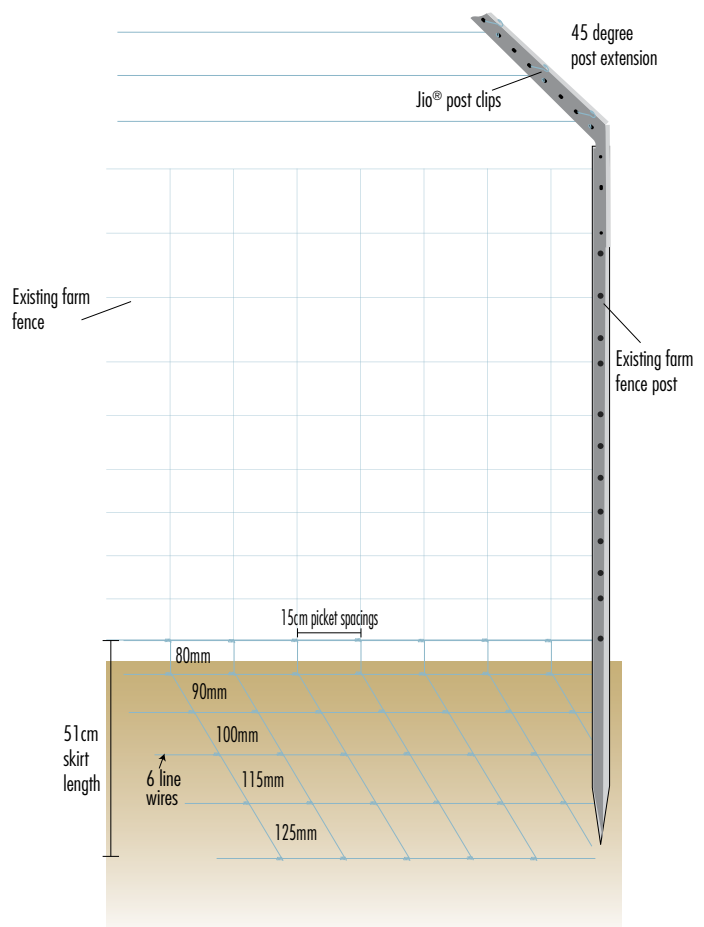



## STOCKSAFE-T® LONGLIFE BLUE® 11/90/15 WITH APRON

The Waratah® Stocksafe-T fence may be used as an internal boundary fence to deter animals such as pigs, wallabies and wild dogs from penetrating the fence line. The apron layout acts as a deterrent to prevent animals from burrowing under the fence.

### FENCE FEATURES

#### Posts:

- > Ezy pipe® strainer post 2.15m
- > Adjusta-stay®
- > 165cm JiO® Star®
- > 180cm JiO MaxY®

#### Wire:

- > Stocksafe-T Longlife Blue 11/90/15 with apron
- > 2.00mm high tensile Longlife Blue barbed wire

#### Accessories:

- > Gripple® T-Clip™
- > JiO post clips
- > Apron strainer extension

#### Tools:

- > Ezy pipe strainer post driver
- > Thumpa® pneumatic post driver
- > Contractor Wizard® wire strainer
- > Contractor Wedgelock® clamp
- > Tenser Senser® wire tensioning gauge

Not compatible with Blue Latch™ post

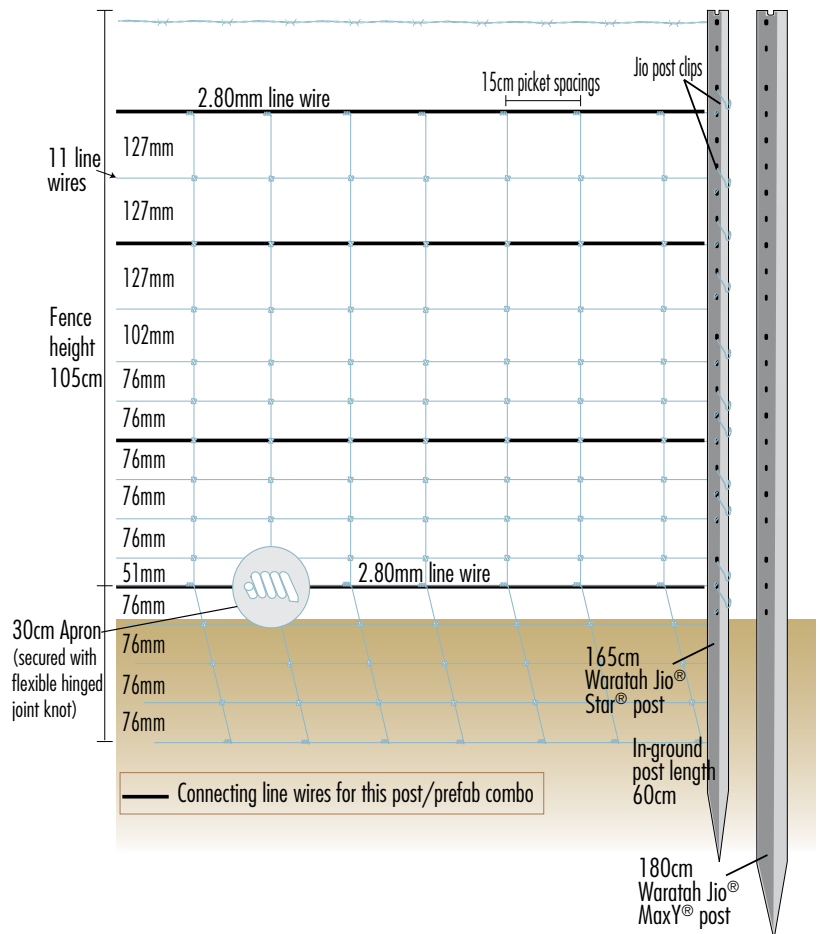



## LOGLIFE BLUE® NETTING – WITH FLOPPY TOP

The Waratah® 3cm mesh spacing netting is commonly used to prevent smaller animals such as baby rabbits (kittens) from breaching the fence line. The netting can be laid as an apron at the bottom of the fence or buried in a trench to prevent animals from burrowing underneath. The floppy top design helps prevent climbing animals such as feral cats and possums from breaching the fence line.

### FENCE FEATURES

#### Posts:

- > JiO® Star® 240cm
- > JiO MaxY® 240cm

#### Wire:

- > Longlife Blue netting 120/3.0/1.40
- > Longlife Blue netting 180/4.0/1.40
- > 2.80mm high tensile Longlife Blue fence wire

#### Accessories:

- > Ringmaster® Longlife Blue clips
- > 3.15mm high tensile cut length tie wire

#### Tools:

- > Ezypipe® strainer post driver
- > Thumpa® pneumatic post driver
- > Ringmaster pneumatic clip gun

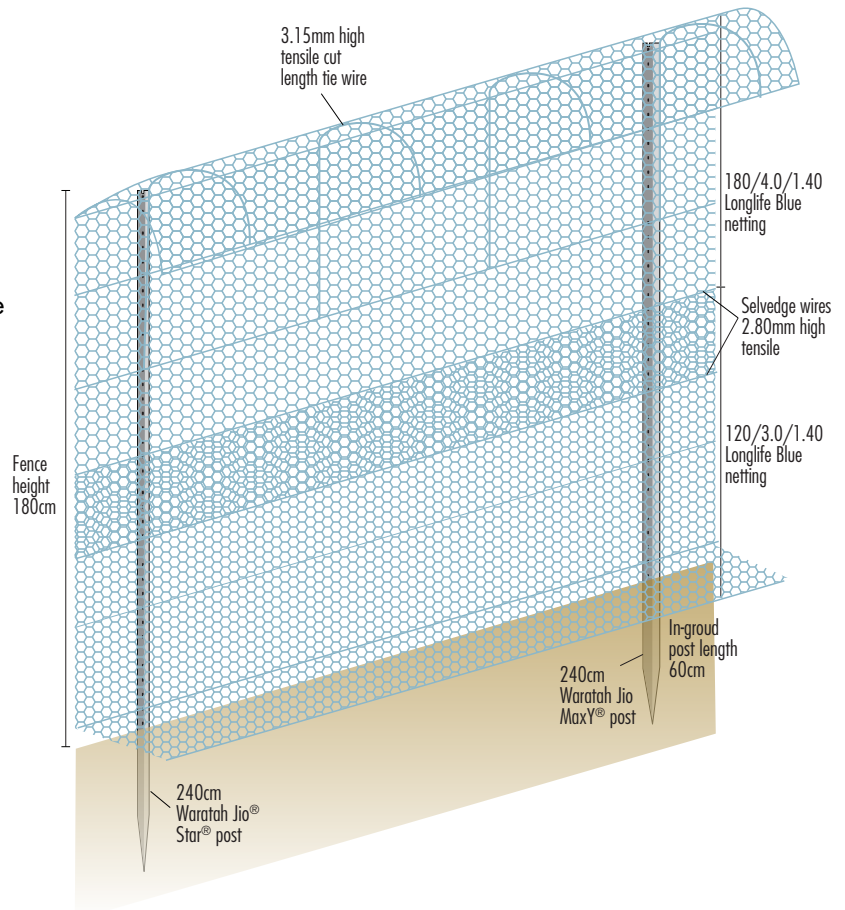



## LOGLIFE BLUE® NETTING – WITH UMBRELLA EXTENSIONS

The Waratah® 1.80mm netting is commonly used in higher pressure applications or highly corrosive environments. The netting can be used as a horizontal application (umbrella extension) at the top of the fence with the use of post extensions or umbrellas to prevent animals jumping or climbing over the fence line. The curved shape helps shed leaves and branches which would otherwise build up on the top of the fence.

### FENCE FEATURES

#### Posts:

- › Ezypipe® strainer post 3.25m
- › Adjusta-stay®
- › 270cm JiO® MaxY®

#### Wire:

- › Longlife Blue netting 180/4.0/1.80
- › Longlife Blue netting 120/3.0/1.40
- › Longlife Blue netting 120/5.0/1.60
- › 2.80mm high tensile Longlife Blue fence wire

#### Accessories:

- › Umbrella JiO post extension 900mm
- › Umbrella strainer post extension 900mm
- › Ringmaster® Longlife Blue clips
- › JiO post clips

#### Tools:

- › Ezypipe strainer post driver
- › Thumpa® pneumatic post driver
- › Ringmaster pneumatic clip gun

Not compatible with Blue Latch™ post

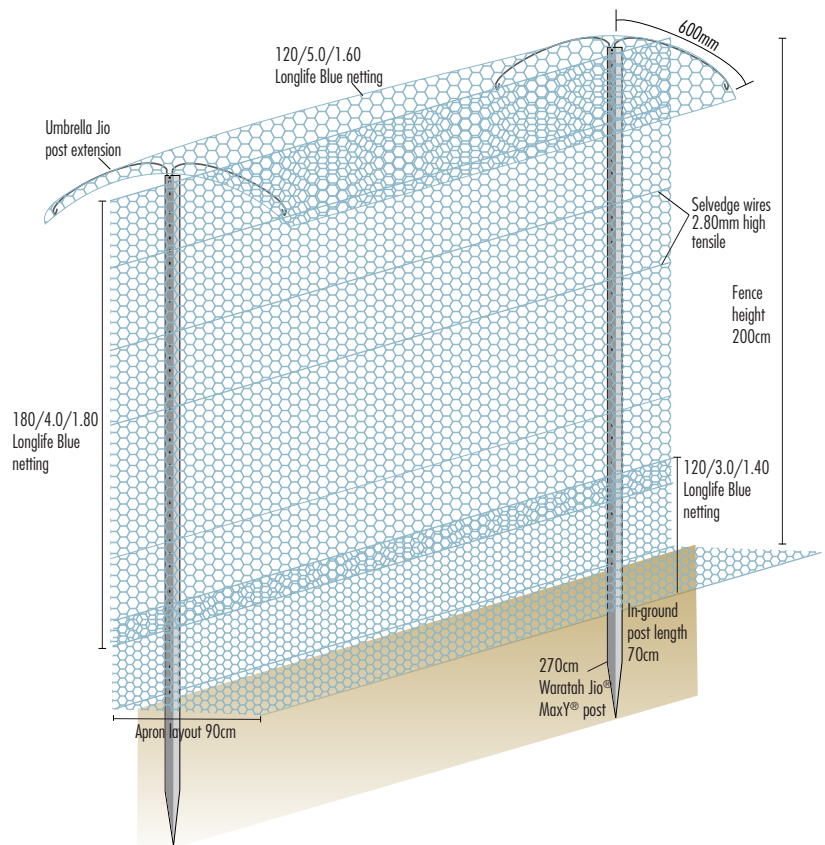



# WARATAH®

## MEANS

# productivity

"Since installing the 2.2km fence, we've increased our stocking rate by one-third, and the fencing has improved our pasture dramatically."



13 10 80



Website



Facebook



YouTube



Prepared by InfraBuild Wire Pty Limited ABN 59 000 010 873. Specifications or technical data referred to in this publication are subject to change, variation and/or improvement without notice and no warranty as to suitability for any use is made. Users of this publication should check all information to satisfy themselves as to its appropriateness and adequacy for their purposes. Unless required by law, the company accepts no responsibility for any loss, damage or consequence resulting from the use of this publication. Photographs are representative only of typical applications. This brochure is not an offer to trade and shall not form part of the trading terms in any transaction. © Copyright 2021 InfraBuild Wire Pty Limited. All Trademarks and Registered Trademarks referred to in this publication are the property of InfraBuild Wire Pty Limited, excluding Gripple, registered to Gripple Ltd. Waratah® guarantees that the Longlife® product range will provide best in class functionality unless abnormally severe corrosive conditions prevail, including use in regions within a few kilometres of surf beaches and polluting sources and where chemical contaminants (e.g. fertilisers) are in use. InfraBuild Wire Pty Limited, Ingall Street, Mayfield, NSW 2304. RQID-1882. Printed January 2021.

Available at:

# SEE WHAT **WARATAH®** FENCING CAN MEAN FOR YOU

## waratahfencing.com.au